

**TERMINAL BOX DETAILS**

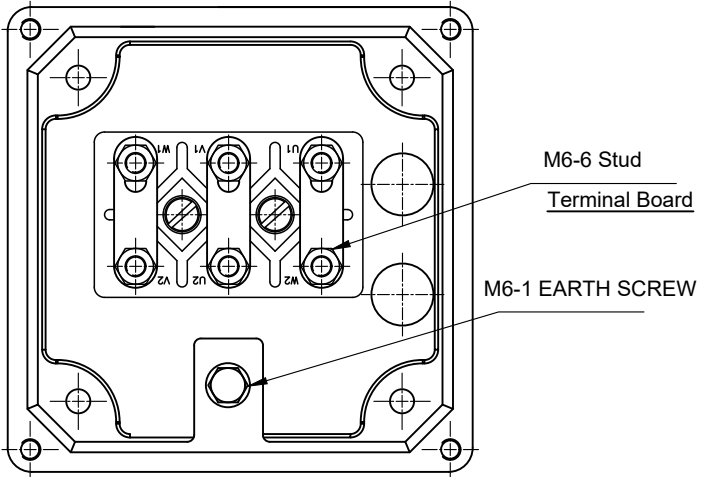

**NAME PLATE DETAILS (IS 12615 : 2018)**

MARKING	CE
Frame	LE 132 M
Duty	S1
Class of insulation	F
Frequency, Hz	50 ±5%
Pole	4
Connectoin	Delta
Output in KW	7.5
Voltage in volts	415 ±10%
F.L.Current in Amps	15.4
Speed in RPM	1430
% Efficiency	88.7(IE2)
Protection	IP-55
Power Factor	0.8
BRG DE	6308 ZZC3
BRG NDE	6307 ZZC3

SAP CODE - 70-0284

ALL DIMENSIONS ARE IN mm					DCR. NO	ZONE	ALTERATIONS	SIGN/ DATE	WEIGHT IN kg.	ROUGH FINISHED	RAW MATERIAL CODE	MODEL	LE 132 M	DRG.No. LE13245002	REV. NO	00
LINEAR DIMENSIONS (MACHINING)	GENERAL TOLERANCES															
	ABOVE	0	30	100	300											
	UPTO	30	100	300	1000											
TOL	±0.2	±0.3	±0.5	±0.8												
ANGLES	± 1/2'															

**LAKSHMI ELECTRICAL DRIVES LIMITED**  
COIMBATORE - 641 004

GA DRAWING  
7.5 KW, 4 POLE, IE2