

TERMINAL BOX DETAILS

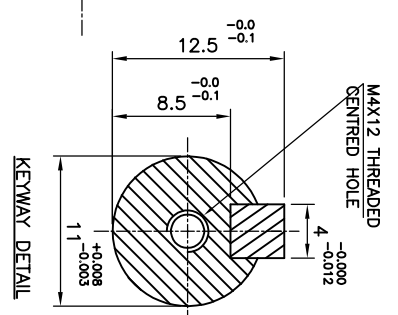
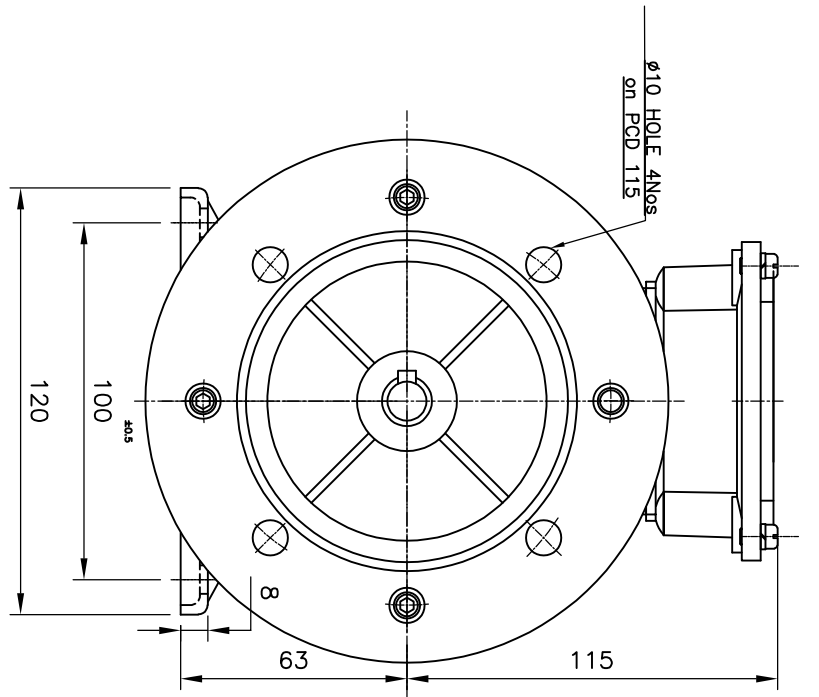
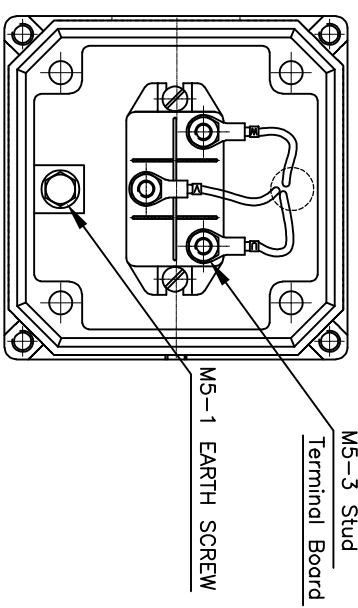

NAME PLATE DETAILS (S12615:2018)

Marking	CE
Frame	LE 63
Duty	S1
Class of Insulation	F
Frequency, Hz	50±5%
Pole	4
Connection	STAR
Output in kW	0.18
Voltage in Volts	415±10%
F.L.Current in Amps	0.82
Speed in RPM	1340
% Efficiency	69.9(IE3)
Brg.(DE)	6202 2RS C3
Brg.(NDE)	6202 2RS C3
Power Factor	0.62
Protection	IP55

ALL DIMENSIONS ARE IN mm

GENERAL TOLERANCES

LINEAR DIMENSIONS (MACHINING)	GENERAL TOLERANCES				
	ABOVE 0	30	100	300	1000
UP TO	30	100	300	1000	
TOL	±0.2	±0.3	±0.5	±0.8	

ANGLES

± 1/2°

DCR NO

ZONE

ALTERATIONS

SIGN/ DATE

WEIGHT IN Kg.

ROUGH

FINISHED

MODEL

LE 63

DRG.No. LEH06346002

REV. NO 00

LAKSHMI ELECTRICAL DRIVES PRIVATE LIMITED
COMBATORRE - 641 004

G.A DRAWING
0.18kW 4P/IE3

